

STL452SUA-3



MATERIAL GROUPS



CHARACTERISTICS

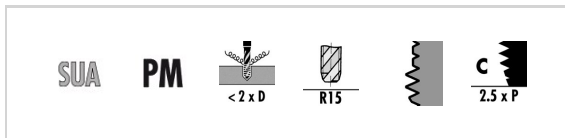



THREADING SOLUTIONS

[watch online](#)

TECHNICAL DRAWING

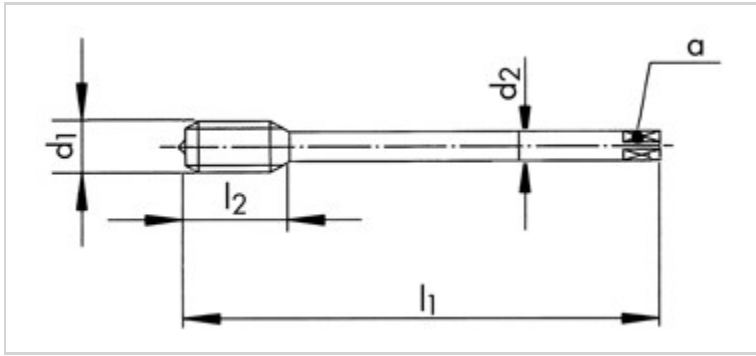

PROFILE SKETCH

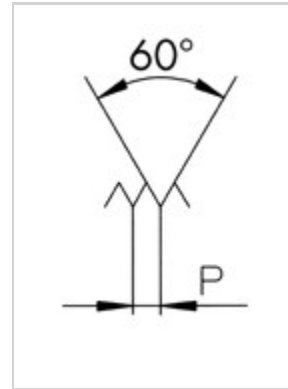

TOOL DATA

ID	D ₁	Ø D ₁	TOL	P	L ₁	L ₂	D ₂	A		
208962	M12	12.00	6HX	1.750	110.0	24.0	9.00	7.0	4	10.20

PRODUCT RANGE STL452SUA-3 M12 6HX

ID	D ₁	Ø D ₁	TOL	P	L ₁	L ₂	D ₂	A		
208962	M12	12.00	6HX	1.750	110.0	24.0	9.00	7.0	4	10.20
208963	M14	14.00	6HX	2.000	110.0	28.0	11.00	9.0	4	12.00
208964	M16	16.00	6HX	2.000	110.0	30.0	12.00	9.0	4	14.00