

CFA80VS

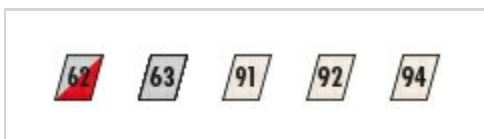

MATERIAL GROUPS



CHARACTERISTICS

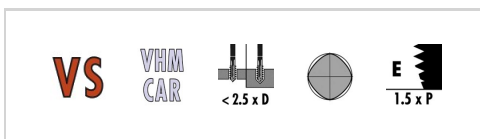



THREADING SOLUTIONS

[watch online](#)

TECHNICAL DRAWING

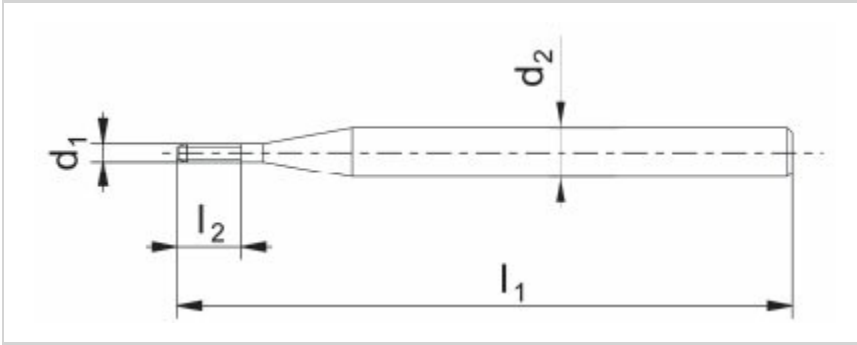

PROFILE SKETCH

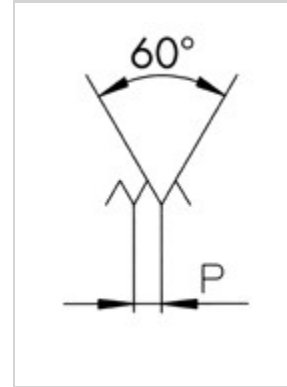

TOOL DATA

ID	D ₁	Ø D ₁	TOL	P	L ₁	L ₂	D ₂		
171782	M1	1.00	4HX	0.250	32.0	3.0	2.00	4	0.88

PRODUCT RANGE CFA80VS M1 4HX

ID	D ₁	Ø D ₁	TOL	P	L ₁	L ₂	D ₂		
171771	M0.5	0.50	4HX	0.125	32.0	1.5	1.50	4	0.44
171773	M0.6	0.60	4HX	0.150	32.0	1.8	1.50	4	0.53
171775	M0.7	0.70	4HX	0.175	32.0	2.1	1.50	4	0.62
171777	M0.8	0.80	4HX	0.200	32.0	2.4	1.50	4	0.71
171779	M0.9	0.90	4HX	0.225	32.0	2.7	1.50	4	0.80
171782	M1	1.00	4HX	0.250	32.0	3.0	2.00	4	0.88
171783	M1.2	1.20	4HX	0.250	32.0	3.6	2.00	4	1.08
171785	M1.4	1.40	4HX	0.300	32.0	4.2	2.00	4	1.25
193590	M1.6	1.60	6HX	0.350	32.0	4.8	2.00	4	1.45
193591	M1.8	1.80	6HX	0.350	32.0	5.4	2.00	4	1.65
193592	M2	2.00	6HX	0.400	39.0	8.0	3.00	4	1.80
193593	M2.3	2.30	6HX	0.400	39.0	9.0	3.00	4	2.10
193594	M2.5	2.50	6HX	0.450	39.0	10.0	3.00	4	2.30
193595	M2.6	2.60	6HX	0.450	39.0	10.0	3.00	4	2.40



THREADING SOLUTIONS

[watch online](#)