

GG353TC-3



MATERIAL GROUPS



CHARACTERISTICS

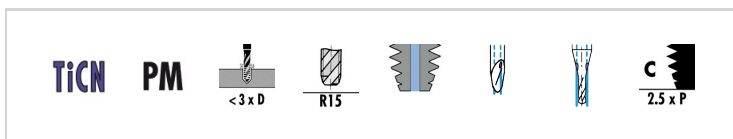



THREADING SOLUTIONS

[watch online](#)

TECHNICAL DRAWING

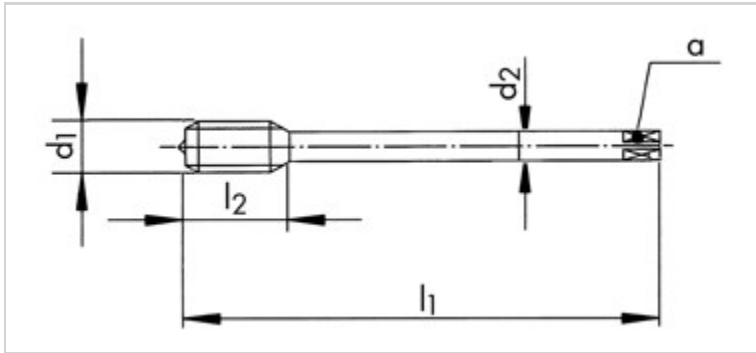

PROFILE SKETCH

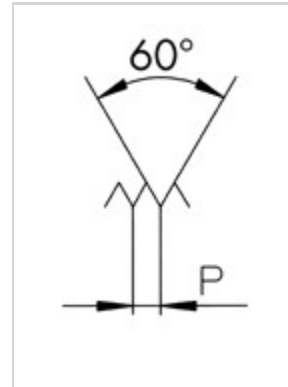

TOOL DATA

ID	D ₁	Ø D ₁	TOL	P	L ₁	L ₂	L ₃	D ₂	A		
147710	M6	6.00	6HX	1.000	80.0	17.0	30	6.00	4.9	3	5.00

PRODUCT RANGE GG353TC-3 M6 6HX

ID	D ₁	Ø D ₁	TOL	P	L ₁	L ₂	L ₃	D ₂	A		
144947	M5	5.00	6HX	0.800	70.0	15.0	25	6.00	4.9	3	4.20
147710	M6	6.00	6HX	1.000	80.0	17.0	30	6.00	4.9	3	5.00
147711	M8	8.00	6HX	1.250	90.0	20.0	35	8.00	6.2	4	6.80
146708	M10	10.00	6HX	1.500	100.0	22.0	39	10.00	8.0	4	8.50